

Silver Cross Dancing Group 190601

The Memorial Hall, Wheathampstead. AL4 8AY....7.30 - 10.45....£5.00/£4.00 for members.... Shared refreshments.

THE NOTE AFTER EACH DANCE IS THE NUMBER OF TIMES IT HAS BEEN ON A PROGRAMME SINCE 1990 AND THE MONTH AND YEAR LAST DANCED.

1 WELCOME TO AYR J32 · 3/4L

Jill Hendricksen/Kathy Stewart: RSCDS XLVII 8 · Crib: MiniCribbs · Diagram: Keith Rose's Diagrams

- 1-8 1s+2s dance double Fig of 8 (1s cross down to start)
- 9-16 1s turn 2s on sides (Men RH, Ladies LH) & 1s dance down to turn 3s on sides (Men RH, Ladies LH) & 1s end facing 1st corners
- 17-24 1s dance 1/2 reel of 4 with corners & pass RSh to face 2nd corner, 1s dance 1/2 reel of 4 with cnrns & 1s end in middle LSh to LSh facing own sides
- 25-32 1M+3s (at top) also 1L+2s dance RH across (1s end in 2nd place opposite sides), all chase clockwise 1/2 way to own sides

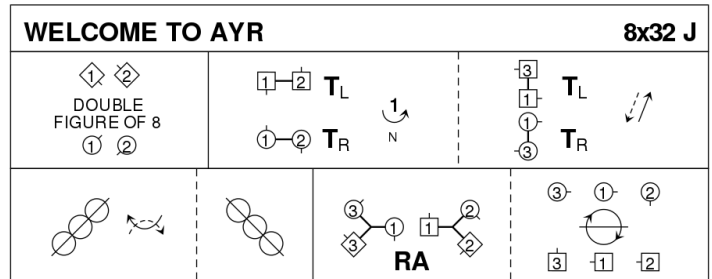

Jill Hendricksen & Kathy Stewart, RSCDS Book 47.8

3C/4C longwise set.

5 APRIL '19

2 THE CAPTAIN'S HOUSE R32 · 3/4L

Holly Boyd: A Third Book of Graded Scottish Country Dances · Crib: MiniCribbs · Diagram: Keith Rose's Diagrams

- 1-8 1s turn RH, cast (2s step up), cross LH to face out in 2nd place opp. sides
- 9-16 2s+1s+3s dance reels of 3 on sides, 1s pass 2nd corner LSh to start. 1s finish facing 1st corners
- 17-24 1s dance 1/2 diag. reel of 4 with 1st corners, pass RSh, dance 1/2 diag. reel of 4 with 2nd corners finishing in 2nd place opp. sides (3) (1) (2)
- 25-32 3s+1s+2s turn partners RH and dance clockwise 1/2 way round set to own sides 2 1 3

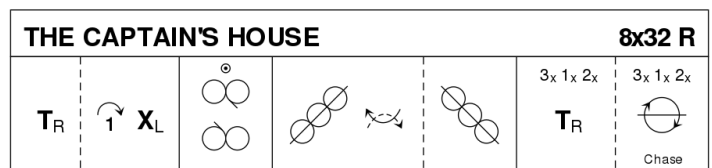

Holly Boyd, 2009, Here's To You Too, RSCDS Graded Book 3.10

3C/4C longwise set.

NEW DANCE

3 THE SWAN AND THE TAY S32 · 3/3L

Audrey Saunders: Scottish Country Dances for Perth 800 · Crib: MiniCribbs · Diagram: Keith Rose's Diagrams

- 1-8 1s dance Figs 8 own sides dancing in & down to start (giving hands where possible)
- 9-16 1s cross down to dance reels of 3 on opp sides (joining hands where possible) & 1s end facing 1st corners, 2s end in 1st place
- 17-20 1s dance Corners Pass+Turn with 1st cnrs, pass RSh on bar 20 to face 2nd cnrs
- 21-24 1s dance Corners Pass+Turn with 2nd cnrs. Pass RSh on bar 24 to end 2nd place own sides
- 25-32 All set, all cross RH, all chase clockwise 1/2 way round to own sides 3 1 2

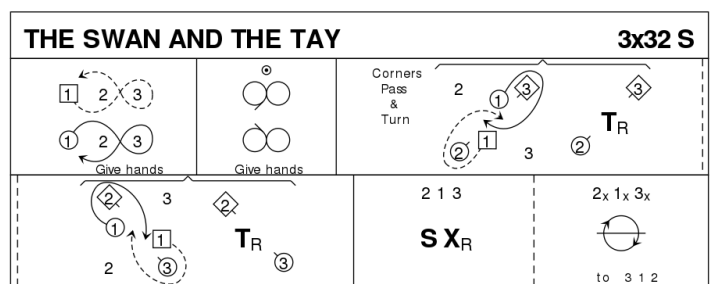

Audrey Saunders, Scottish Country Dances for Perth 800

3C/3C longwise set.

5 APRIL '19

4 THE SHIP IN FULL SAIL J32 · 5/5L

Bill Forbes: Craigievar Book 2 · Crib: MiniCribs · Diagram: Keith Rose's Diagrams

- 1-2 1s & 3s cross down 1 place RH (1M/3M face down to next Lady & 1L/3L face up to Man above **while** 2L faces 5M)
- 3-6 All set, 2L/5M stand as others 3/4 turn RH to lines across (1L b'tw'n 2s face down, 3M b'tw'n 5s face up, 1M+3L b'tw'n 4s)
- 7-8 Top & bottom lines set as centre 4 Bal-in-Line
- 9-16 1s & 3s turn to right & dance reels across (reels of 3 at ends & reel of 4 in middle), 1s & 3s end facing their 2nd corners (LSh to LSh)
- 17-24 1s & 3s set to 2nd corner & turn inwards to face partners 2nd crnr & set, rotate clockwise to face ptrns 1st crnr & set & turn about to set to own 1st crnr
- 25-32 All dance RH across (1L with 2s, 1M+3L with 4s & 3M with 5s), 1s & 3s turn partners LH & cast down 1 place

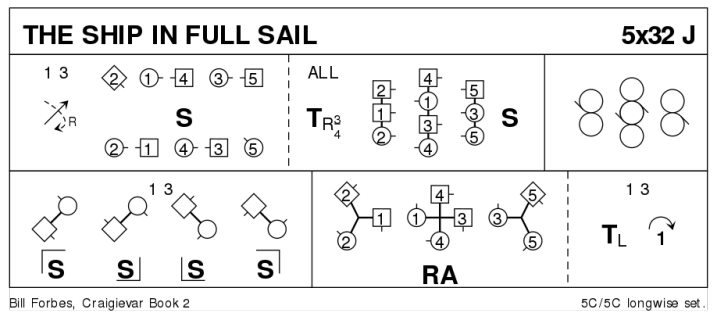

9 FEB '15

5 THE EARL OF MANSFIELD R48 · 4/4L

John Drewry: The Leaflet Dances with Music · Crib: MiniCribs · Diagram: Keith Rose's Diagrams

- 1-8 1s+2s circle 4H round & back
- 9-16 1s+2s also 3s+4s face on sides, all set & change places RH, all set & change back RH
- 17-24 1M reel of 3 with 2s (LSh to 2L) picking up partner in prom hold to complete reel as 3M dances similarly with 4s, 1s+3s end on Men's side
- 25-32 3s followed by 1s dance down below 4s, 3s cast, in & lead up to top, cross & cast back to place **while** 1s cast up & turn LH to face 1st crnrs
- 33-40 1s turn 1st corners RH pass partner RSh, turn 2nd corner LH, pass LSh to end 2nd place in centre facing up
- 41-48 1L+2L+3L dance RH across (on side) as 1M+2M+3M LH across, 1s followed by 3s dance down to 4s & Ladies dance LH across as Men RH across to end 2 3 4 1

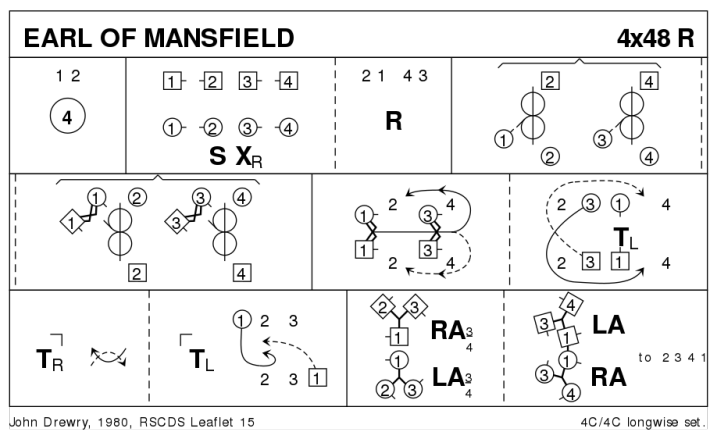

31MAR '19

6 THE BLUE MESS JACKET S32 · 4/4L

Douglas Henderson: Kinclaven Pocket Book of Six Scottish Country Dances · Crib: MiniCribs · Diagram: Keith Rose's Diagrams

- 1-8 2s followed by 1s lead down the middle, 1s cross & cast up to top & turn in to face 2s who have danced back to place
- 9-16 1s dance 1/2 reel of 4 with 2s & 1/2 turn partner RH to face 3s, 1s dance 1/2 reel of 4 with 3s & 1/2 turn partner RH to face 4s
- 17-24 1s dance 1/2 reel of 4 with 4s & 1/2 turn RH & continue turn to end in 4th place opposite sides & all set
- 25-32 All Petronella to centre & set, Petronella to own sides & set

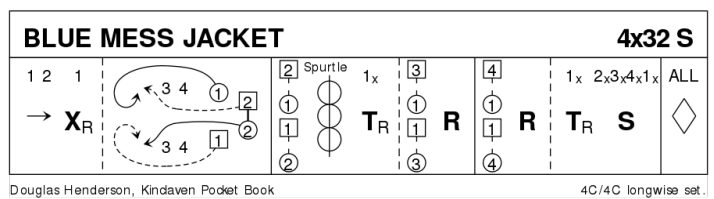

26 DEC '18

7 SETON'S CEILIDH BAND J64 · 4/4L

A Bruce Fordyce: The Bruce Fordyce Memorial Collection · Crib: MiniCribs · Diagram: Keith Rose's Diagrams

- 1-8 1s cross RH & cast 1 place (2 step up), dance down between 3s (3s step up) & cast down behind 4s to 4th place (4s step up)
- 9-16 1s dance reflection reels of 3 on opposite sides (1s in/up, 4s out/down)
- 17-24 1s cross RH & cast up 1 place, lead up between 3s & cast up behind 2s to 1st place own sides
- 25-32 1s dance reflection reels of 3 on own sides (1s in down, 2s out/up)
- 33-40 1s cross RH & cast down 1 place (2 step up) 1s give RH to partner & LH to 1st corners, Bal-in-Line & turn partner RH to give LH to 2nd corners
- 41-48 Bal-in-Line & 1s dance out & cast down behind 3s, meet & lead up to top crossing to 1st place own sides (2s step down)
- 49-60 1L+2L & 1M+2M change places RH on sides & 2s+1s cross over LH, repeat with 3s & 4s until reaching the bottom of the set
- 61-64 All turn partners RH 1.1/2 times

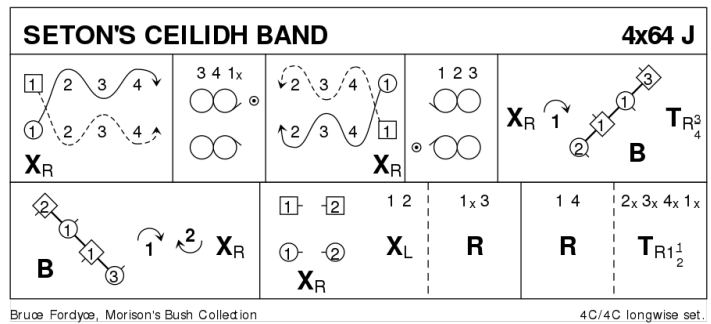

31 DEC '17

8 "DEER" FRIENDS S32 · 3/4L

Bob Anderson: The Saint Martin Coll. of New Scottish Country Dances vol. 1 · Crib: MiniCribs · Diagram: Keith Rose's Diagrams

- 1-8 1s cross down RH, cast behind 3s, cross RH, cast up 1 place, turn 3/4 LH to join RH with 3rd corners in a diagonal line
- 9-12 Balance in Line figure:
 9 All set 1 step Right, change hands so that 1s and 3rd corners take LH
 10 1s and 3rd corners 1/2 turn LH, retain LH and 1s join RH in middle of line
 11 All set 1 step R, 1s join LH & drop hands with corners
 12 1s 1/2 turn LH to face 3rd corners **while** corners set 1 step Left turning to face diagonally in
- 13-16 1s dance 1/2 diagonal reel of 4 with 3rd corners, finish facing 4th corners
- 17-24 Repeat bars 9-16 with 4th corners, 1s crossing LH to finish in 2nd place opp sides End (3)(1)(2)
- 25-32 Set and link for 3 couples twice to finish 213 on own sides

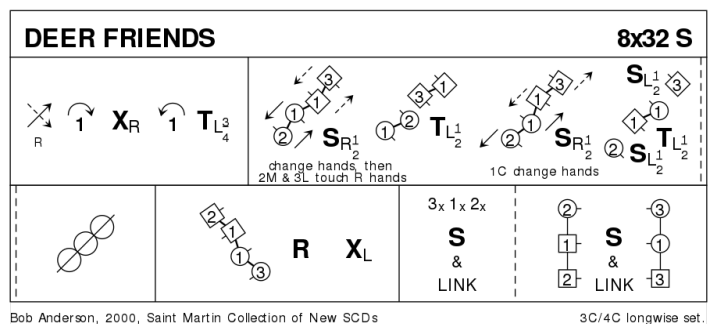

3 FEB '19

9 RAMADAN-CE R32 · 3/4L

John Drewry: The Turkish Set · Crib: MiniCribs · Diagram: Keith Rose's Diagrams

- 1-8 1s dance Inveran Reels with 2s+3s
- 9-16 1s cross RH, cast 1 place & turn RH to face 1st corners
- 17-24 1s dance RSh round 1st corner, pass RSh & dance RSh round 2nd corner to end 2nd place opposite side **while** 1st corners dance in, 1/2 turn RH, twirl & dance out to each others place, 2nd corners dance similarly. (3)(1)(2)
- 25-32 1s dance 1/2 LSh reels of 3 across (Man at top with 3s & Lady at bottom with 2s), 1s dance 1/2 RSh reels of 3 on own sides (Man Down, Lady up)

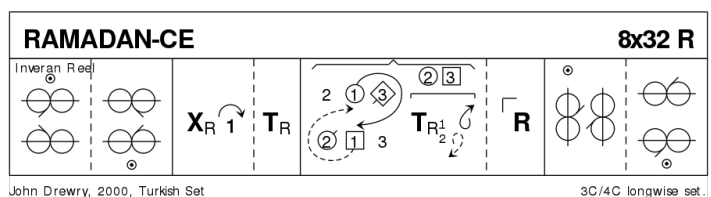

11 MAR '19

INTERVAL

10 TORRIDON LASSIES J40 · 3/4L

John Brenchley: *The Kangaroo Paw* · Crib: *MiniCribs* · Diagram: *Keith Rose's Diagrams*

- 1-8 1s cross & cast 1 place, 1s dance LH across (1L with 2s, 1M with 3s) & end facing 4th corner
- 9-16 1s set to corners then to partner up/down the dance & end facing 1st corners, turn corners RH & pass partner LSh to face 2nd corners
- 17-24 1s dance 1/2 diagonal reel of 4 with 2nd corners & pass LSh to face 3rd corners, 1s set to corners then set to partner across the dance & end facing 4th corners
- 25-32 1s turn 4th corner (pstrn) RH & pass partner LSh to face 1st corners, 1s dance 1/2 diag reel of 4 with 1st corners & pass RSh to BtoB (1M facing up)
- 33-40 1s dance RSh round 2nd corners & 1/2 Fig 8 (1L up, 1M down) **while** 2s+3s set & cross RH, set (facing up/down) & change pl RH on sides. 2 1 3

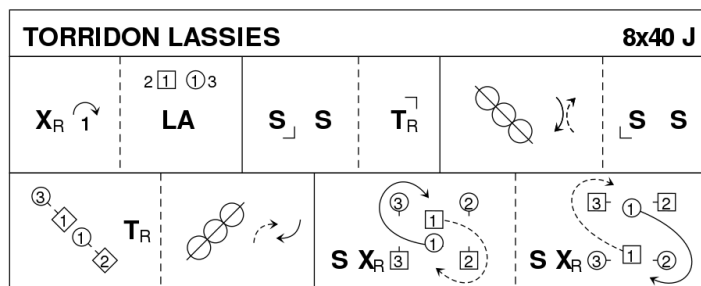

John Brenchley, 2006, *The Kangaroo Paw*

3C/4C longwise set.

20 MAY '19

11 TOSSON HILL R32 · 3/4L

Patricia Cass: *Life Begins at Forty* · Crib: *MiniCribs* · Diagram: *Keith Rose's Diagrams*

- 18 1s cross RH, cast 1 place & turn LH
- 916 1s dance RH across (Lady with 2s & Man with 3s), 1s pass RSh to dance LH across with other couple
- 1724 1s dance reels of 3 on opposite sides giving RSh to 1st corners, 1s pass RSh to end BtoB facing own sides
- 2532 1s dance Double Triangle

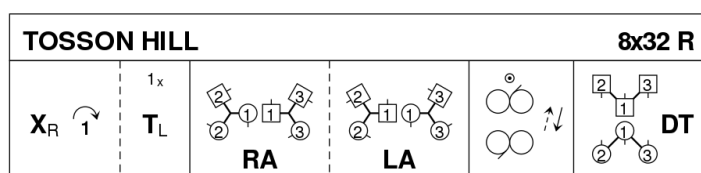

Patricia Cass, *Life Begins at Forty*

3C/4C longwise set.

NEW DANCE

12 THE WIND ON LOCH FYNE S32 · 3T

John Bowie Dickson: *Dunedin Dances Book 1* · Crib: *MiniCribs* · Diagram: *Keith Rose's Diagrams*

- 1-8 1s cross over (Man between 3s, Lady between 2s) & dance Fig of 8 & end turning RH 1/2 way to face partner in original places
- 9-16 All dance interlocking RSh reels of 4 & end by turning RH to bring Men into centre
- 17-24 Men dance LH across in centre 2 places **while** Ladies dance clockwise 1 place, turn partner RH & repeat ending in triangular set order 2 3 1
- 25-32 All set & circle 6H round for 2 steps, turn partner 2H & continue to circle 6H round to pstrns. 2 3 1

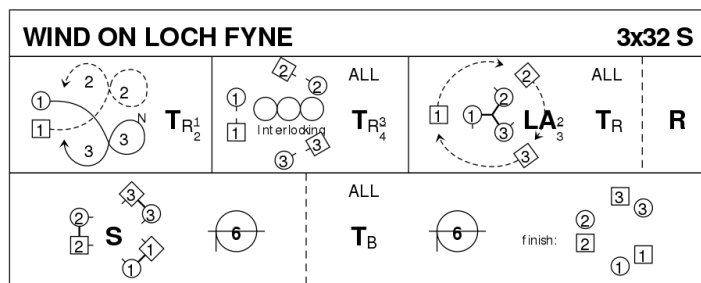

John Bowie Dickson, 1986, *Dunedin 1*

3C/3C triangular set.

13 APRIL '18

13 THE TATTIE BOGLE J32 · 3/4L

Derek Haynes: *Carnforth Collection of SC Dances 1* · Crib: *MiniCribs* · Diagram: *Keith Rose's Diagrams*

- 1-8 1s set, cross down RH & face partner, set & turn LH to face 1st corners
- 9-16 1s set to 1st corners, full turn corner RH to dance 1/2 diagonal reel of 4 with 1st corners & pass LSh to face 2nd corners
- 17-24 1s set to 2nd corners, full turn corner RH to dance a 1/2 diagonal reel of 4 with 2nd corners & into centre
- 25-32 1M dances RH across with 3s (in 1st place) & 1L dances with 2s, 1s end in 2nd place opposite sides & 2s+1s+3s chase clockwise 1/2 way

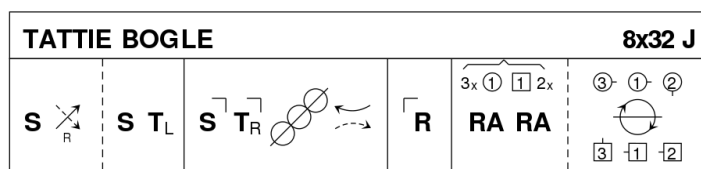

Derek Haynes, 1991, *Carnforth Collection*

3C/4C longwise set.

5 JUNE '18

14 POLHARROW BURN R32 · 5/5L

Hugh Foss: Magazine Dances 2005-2009 · Crib: MiniCribs · Diagram: Keith Rose's Diagrams

- 1-8 1s & 3s cross RH, cast 1 place (2s & 4s step up) & dance 1/2 Fig of 8 round couple above them
- 9-16 1s & 3s turn RH then turn LH (long turns) to face 1st corners **while** 2s & 5s change places RH & chase clockwise to other end of set
- 17-24 1s & 3s dance 1/2 diag reels of 4 with 1st corners, pass partner LSh, dance 1/2 diag reels of 4 with 2nd corners
- 25-32 1s & 3s dance 1/2 diag reels of 4 with 3rd corner, turn partner LH & cast down 1 place own sides. 2 4 1 5 3

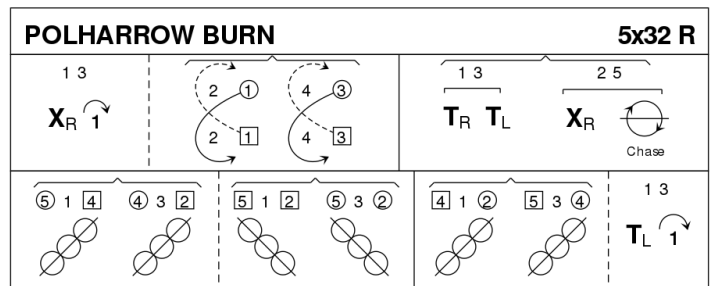

Hugh Foss, 1967, Glendarragh S D Sheets, www.dancearchives.co.uk 5C/5C longwise set.

26 MAR '19

15 MRS MILNE OF KINNEFF S32 · 4S

Alan Macpherson: The Leaflet Dances with Music · Crib: MiniCribs · Diagram: Keith Rose's Diagrams

- 1-8 1s & 3s join hands with partner & adv for 2 steps, turn opposite partner RH once round, retaining opp ptr hand dance RH across with 2s/4s
- 9-16 Dancing couples (1M+3L & 1L+3M) facing side couples dance parallel reels of 4 across the dance
- 17-18 Dancing couples (1M+3L & 1L+3M) set to side couples
- 19-22 Dancing couples (1M+3L & 1L+3M) dance out between side couples & cast to original places **while** side couples separate & dance into centre to meet partners then holding nearer hands dance out to original places
- 23-24 All turn partners 2H
- 25-32 All circle 8H 1/2 way round to left, 3/4 turn partners RH into prom hold (Ladies on inside) & all Promenade 1 place clockwise

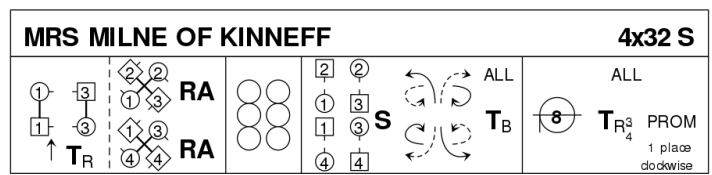

Alan Macpherson, RSCDS Leaflet 32 4C/4C square set.

8 JAN '07

16 QUARRIES' JIG J32 · 3/4L

Kent W Smith: RSCDS XXXVI 3 · Crib: MiniCribs · Diagram: Keith Rose's Diagrams

- 1-8 1s set, cast 1 place & dance round 1st corners passing corners LSh
- 9-16 1s dance reels of 3 across (1st Man with 2s & 1st Lady with 3s), 1s turn LH to face 1st corners
- 17-18 Centre dancers change with 1st corners RH **while** 2nd corners set
- 19-20 1st corners (in centre) change places LH **while** new 1st & 2nd corners dance clockwise round to next corner place
- 21-24 Repeat the Fig in bars 17-20 from new places
- 25-32 Repeat 17-20 from new places, 1s end by turning LH to 2nd place on opposite sides, 2s+1s+3s set on sides & 1s cross back RH

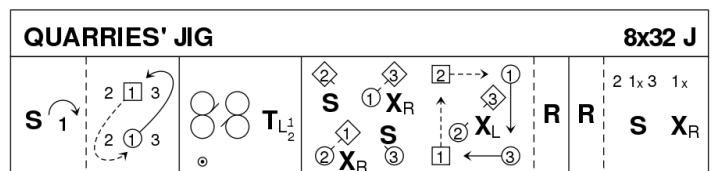

Kent W Smith, RSCDS Book 36.3 3C/4C longwise set.

30 OCT '16

17 JOHN MCALPIN S32 · 3/4L

Hugh Foss: Magazine Dances 2005-2009 · Crib: MiniCribs · Diagram: Keith Rose's Diagrams

- 1-8 1s Adv+Ret 1 step (touch RH) & cross LH, lead down RH 1 place & 3/4 turn LH to face 1st corners
- 9-16 1s turn RH 1st corner & turn partner LH, turn RH 2nd corner then cross LH to 2nd place own sides
- 17-24 2L+1L+3L set, Adv+Ret & set **while** 2M+1M+3M stand for 2 bars, set, Adv+Ret
- 25-32 2s+1s+3s cross RH, circle 6H round to left 1/2 way, cross LH & circle 6H round to right 1/2 way

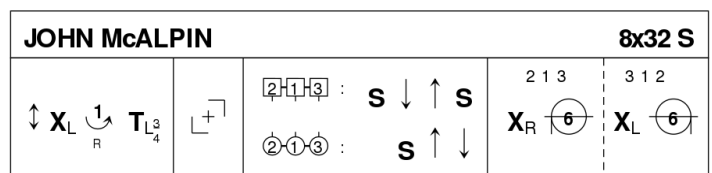

Hugh Foss, Galloway Album, RSCDS 3 Foss, Magazine 2005-2009 3C/4C longwise set.

9 OCT '16

18 THE MONTGOMERIES' RANT R32 · 3/4L

Castle Menzies (18C): RSCDS X 1 · Crib: MiniCribs · Diagram: Keith Rose's Diagrams

- 1-8** 1s cross RH & cast down to 2nd place (2s step up), cross LH & 1L casts up **while** 1M casts down
- 9-16** 1s dance reels of 3 across, 1L with 2s (RSh to 2M) & 1M with 3s (RSh to 3L)
- 17-24** 1s NHJ (Lady on Mans left) set to 2L & turn inwards to set to 3M, set to 3L & turn inward & set to 2M. End facing own 2nd corner (1L pull back LSh to face down)
- 25-32** 2s+1s+3s dance reels of 3 on opposite sides 1s giving RSh to 2nd corner, 1s cross RH to 2nd place own sides

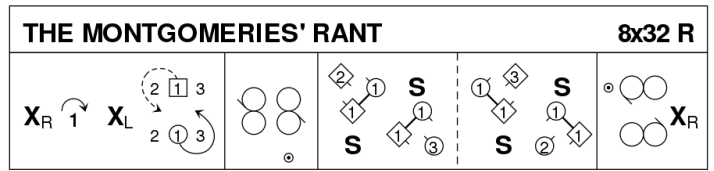

Castle Menzies, 1749, RSCDS Book 10.1

3C/4C longwise set.

34 JUN 18